

YC-650EL

New Product
Intelligent Control & Constant Temperature
Multiple Alarms Bring More Security

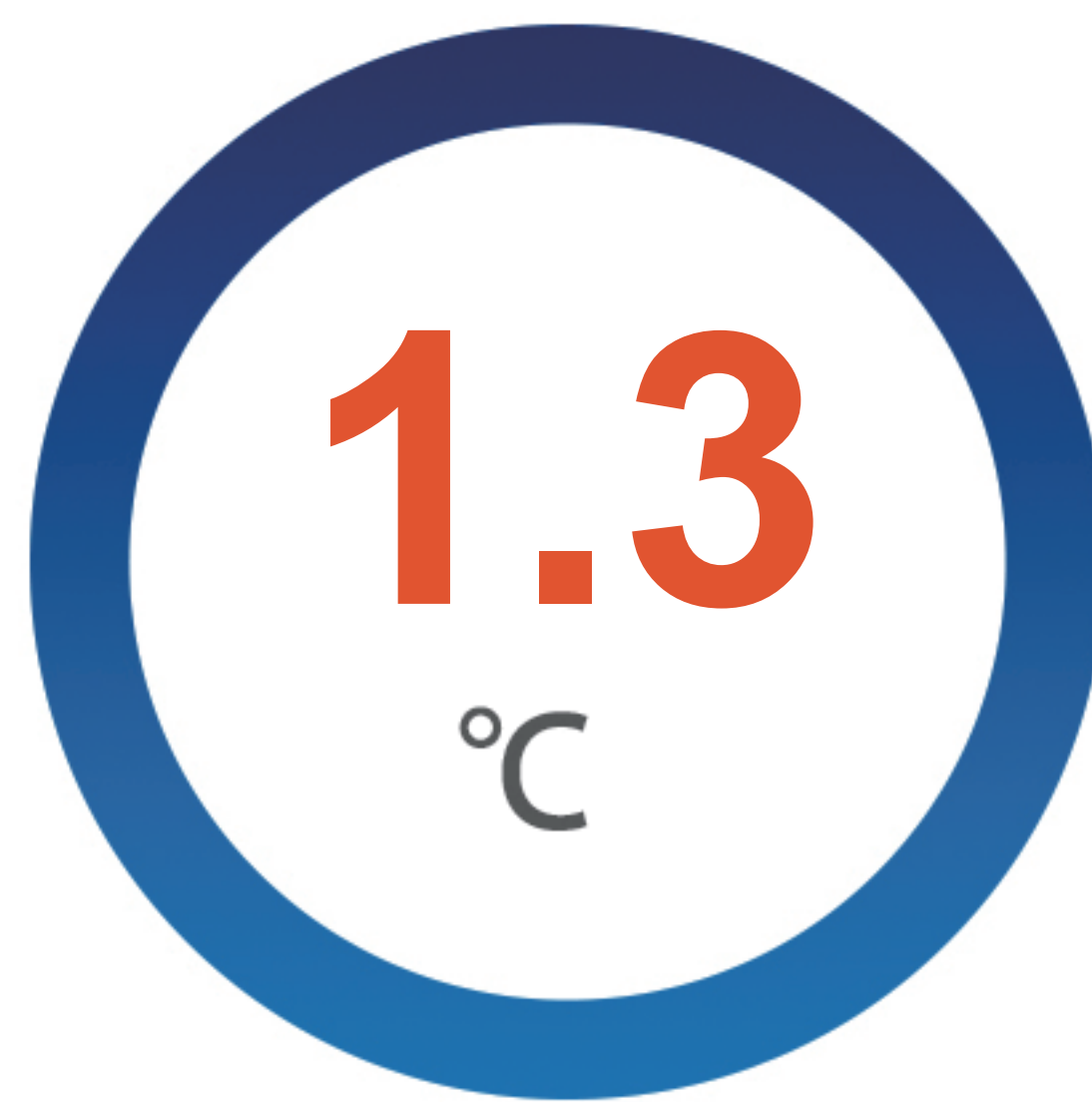

Temp.Uniformity



Pulling down to 5°C



Temp. recovery after door opened for 1 min

**Typical freezer data based on internal testing with freezer set point at 5°C and ambient temperature at 25°C.*

Features

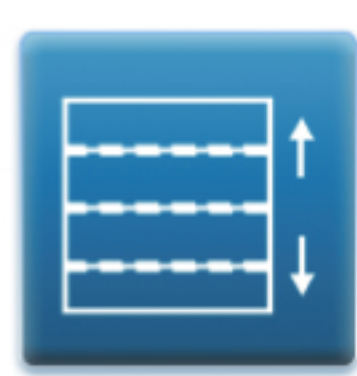

Adjustable shelves' heights



ENERGY STAR certificate



Hydrocarbon refrigerant
Environment-friendly natural gas



CE certificate



Temperature control system
Display temp. in 0.1°C increments



Alarms system
Multiple alarm functions

Structure

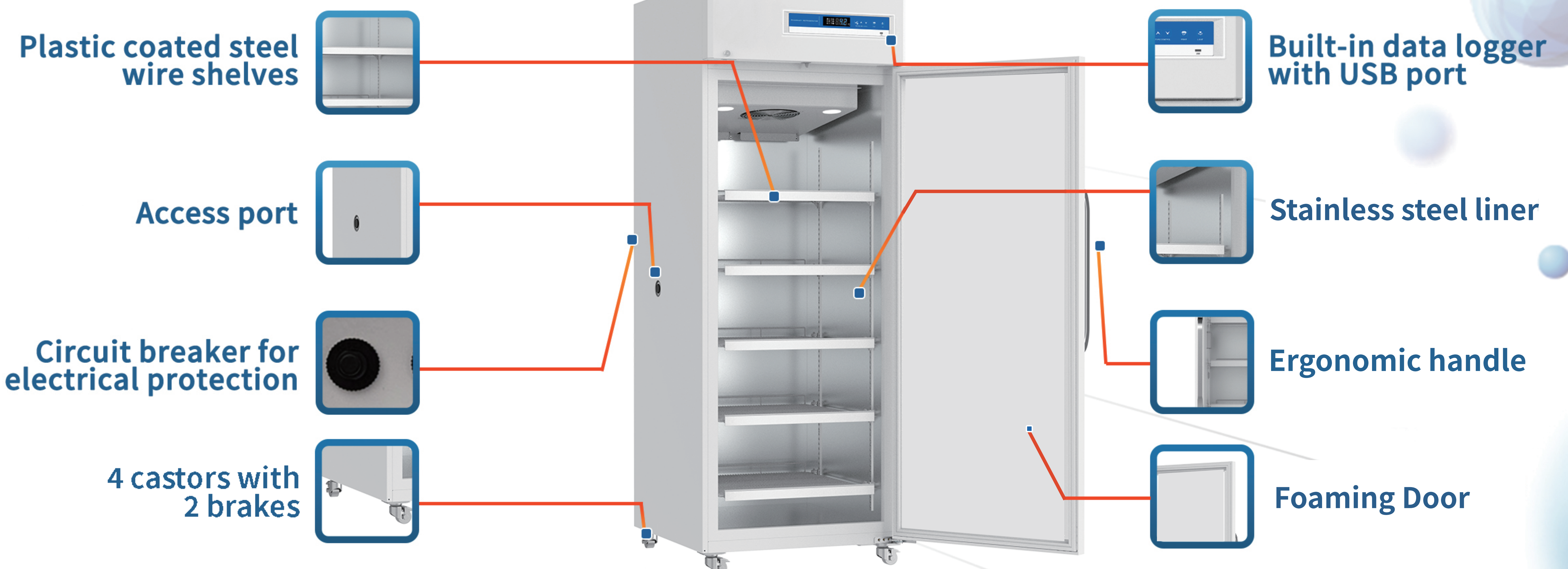

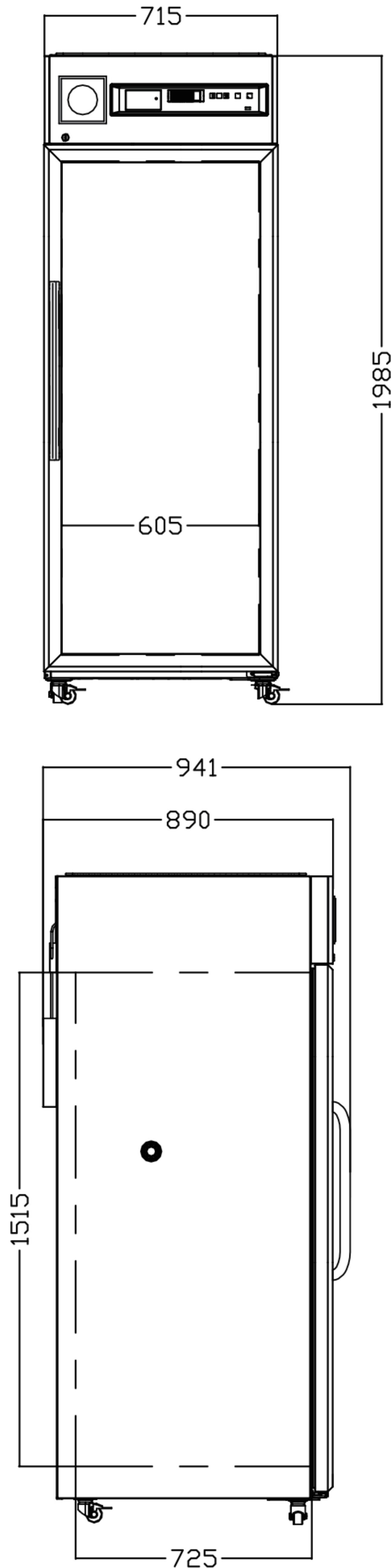

2~8°C Pharmacy Refrigerator

Model	YC-650EL
Capacity	650L/22.95Cu.Ft
Internal Size (W*D*H) mm	605×725×1515/23.82*28.54*59.65
External Size (W*D*H) mm	715*890*1985/28.15*35.04*78.15
Package Size (W*D*H) mm	773*947*2154/30.43*37.28*84.8
NW/GW (kgs)	148/176
Performance	
Temperature Range	2~8°C
Ambient Temperature	16~32°C
Cooling Performance	5°C
Climate Class	N
Controller	Microprocessor
Display	7"HD IntelligentTouch Screen
Refrigeration	
Compressor	1pc
Cooling Method	Air Cooling
Defrost Mode	Automatical
Refrigerant	R290
Insulation Thickness(mm)	D:62, L/R:55, B:55, U/D:55/62
Construction	
External Material	PCM
Inner Material	Stainless Steel
Shelves	5
Access Test Port	1pc. Ø 23mm
Casters	4(2 brakes)
Data Logging/Export	Record every 10 mins/Max.12 months via USB port
Interface	Remote Alarm Contact, RS485
Backup Battery	Yes
Alarms	
Temperature	High/Low Temperature, High Ambient Temperature, Condenser High Temperature Alarm
Electrical	Power Failure, Low Battery, Sensor Error
System	Data Communication Failure, Door Ajar,Data Logger Failure
Electrical	
Power Supply(V/Hz)	220-240V;50/60Hz
Rated Current(A)	1.67A

*Zhongke Meiling reserves the right to change products and specifications without prior notice.